

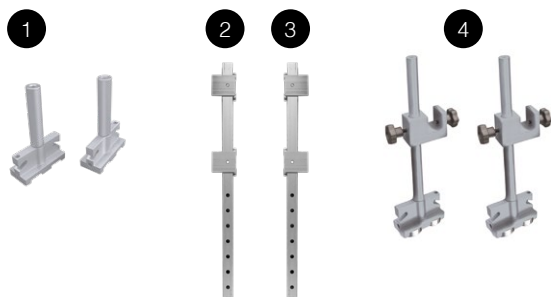

AM 1330 K/10150 Magnet hanger kit Magnetupphängningssats Magnetaufhängesatz für Nfz

#	Article #	Order #	Pcs.	EN	SE	DE
1	TC-1029	71349	2	Magnet bracket for frame gauge	Magnetfäste för mätlinjal	Magnethalter für Messlineal
2	AM1227-1 A	10234	1	Magnet bracket for frame, right	Magnetfäste för ram, höger	Magnethalter für Rahmen, rechts
3	AM1227-2 A	10235	1	Magnet bracket f frame, left	Magnetfäste för ram, vänster	Magnethalter für Rahmen, links
4	15439	70693	2	Magnet Bracket	Magnetfäste	Magnethalter



Stabilizers Gungskydd Feststelleadapter

#	Article #	Order #	Pcs.	EN	SE	DE
1	JT485	12017	1	Stabilizer	Gungskydd	Feststelleadapter
2	JT119	11903	1	Stabilizer for frame	Gungskydd för ram	Feststelladapter für Rahmen

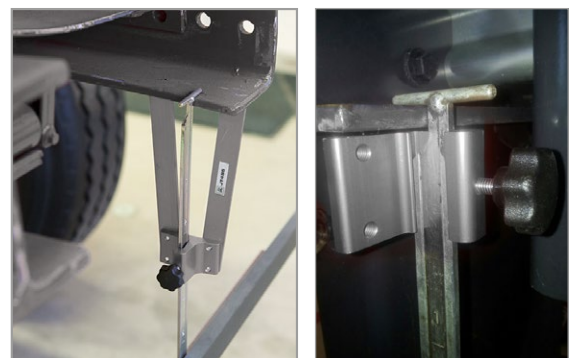
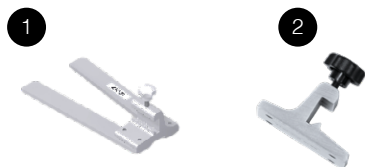

2 pcs of JT485 or JT119 are needed.

2 st JT485 eller JT119 behövs.

2 Stück JT485 oder JT119 sind notwendig.



CA BUS K/72244

Additional kit for buses — JOSAM cam-aligner

Tilläggsats för bussar — JOSAM cam-aligner

Ergänzungssatz für Busse — JOSAM cam-aligner



#	Article #	Order #	Pcs.	EN	SE	DE
1	12278	70473	2	Round bar	Rundstång	Rundstange
2	15439	70693	4	Magnet Bracket	Magnetfäste	Magnethalter
3	15490	70706	4	Vacuum bracket	Sugkopp	Saugteller
4	16456	70844	4	Steel Plate	Stålpatta	Stahlplatte
5	16506	70849	2	Lock	Lås	Schloss
6	CA1026	72026	4	Gauge extension	Mätstång	Mess-Stange

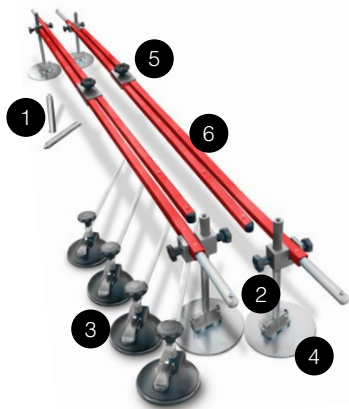

AM BUS K/15877

Additional kit for buses — JOSAM laser AM/truckaligner

Tilläggsats för bussar — JOSAM laser AM/truckaligner

Ergänzungssatz für Busse — JOSAM laser AM/truckaligner



#	Article #	Order #	Pcs.	EN	SE	DE
1	AM1294	10251	2	Joint rail, complete	Skarvskena komplett	Mess-Stangen Verbinder
2	12278	70473	2	Round bar	Rundstång	Rundstange
3	15439	70693	4	Magnet Bracket	Magnetfäste	Magnethalter
4	15490	70706	4	Vacuum bracket	Sugkopp	Saugteller
5	16456	70844	4	Steel Plate	Stålpatta	Stahlplatte





Most buses, coaches and mini buses are built with an integrated body structure design, without a symmetric chassis frame structure. Furthermore, the bodywork of buses and coaches are made of materials like aluminium, plastic and stainless steel. This makes it hard to use magnet adapters. Using the self centering bus adapters solves these problems.

De flesta stadsbussar, långfärdsbussar och minibussar har självbärande karosser. Dessutom förekommer det att karossen är gjord av aluminium, plast eller rostfritt stål, vilket gör det svårt att använda magnetiska upphängare.

Detta kan lösas genom att använda de självcentrerande bussadapterna.

Die meisten Stadt-, Linien- und Minibusse bestehen aus einer Karosseriekonstruktion die nicht wie bei normalen LKW auf einer symmetrischen Rahmenstruktur aufbaut. Der Aufbau besteht häufig aus Aluminium, Plastik oder nichtrostenden Stählen; daher können keine Magnet-Adapter eingesetzt werden. Selbstzentrierende Adapter für Busse lösen diese Probleme.



TC-101-2/70026

Kit with self centering bus adapter

Sats med självcentrerande bussadapter

Selbstzentrierender Adapter für Busse

#	Article #	Order #	Pcs.	EN	SE	DE
1	TC-101	-	2	Self centering bus adapter	Självcentrerande bussadapter	Selbstzentrierender Adapter für Busse

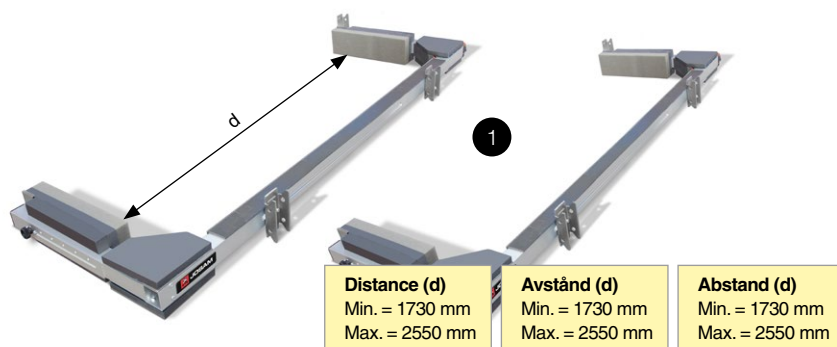

TC-111-2/71646

Kit with self centering minibus adapter

Sats med självcentrerande minibussadapter

Selbstzentrierender Adapter für Minibusse



#	Article #	Order #	Pcs.	EN	SE	DE
1	TC-111	-	2	Self centering minibus adapter	Självcentrerande minibuss-adapter	Selbstzentrierender Adapter für Minibusse

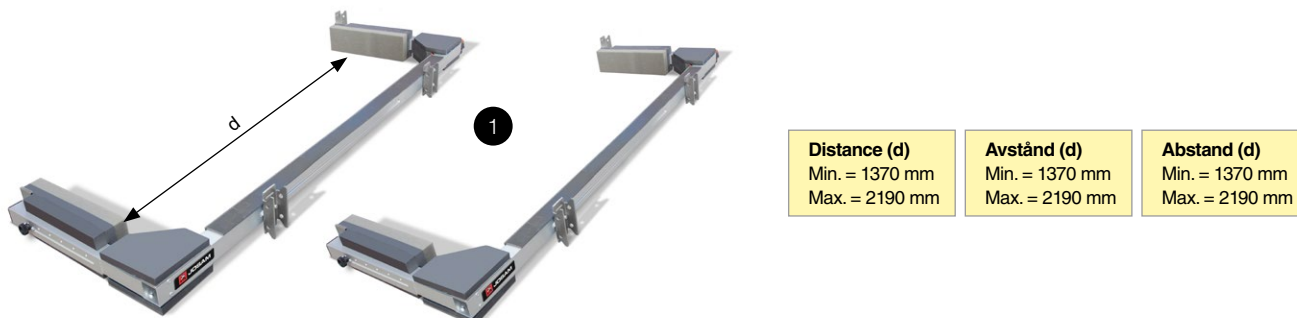



CA TRAILER K/72104

Additional kit for trailer and semi-trailer

Tilläggsats för släp och semi-trailer

Ergänzungssatz für Anhänger und Auflieger



#	Article #	Order #	Pcs.	EN	SE	DE
1	JT510	12029	1	Adapter for bumper	Adapter för stötfångare	Adapter für Stosstange
2	JT167	11928	1	Bracket for "king-pin"	Fäste för "king-pin"	Halter für "king-pin"
3	AM48 A	10579	1	Adapter for trailer tow bar	Adapter för släpvagnsögla	Adapter für Zuggabel
4	JT485	12017	2	Stabilizer for JT510 + JT167	Gungskydd för JT510 + JT167	Feststelladapter f. JT510 + JT167
5	JT5-8	12046	2	Hanger 870 mm	Upphångningsstång 870 mm	Aufhänge-Stange 870 mm

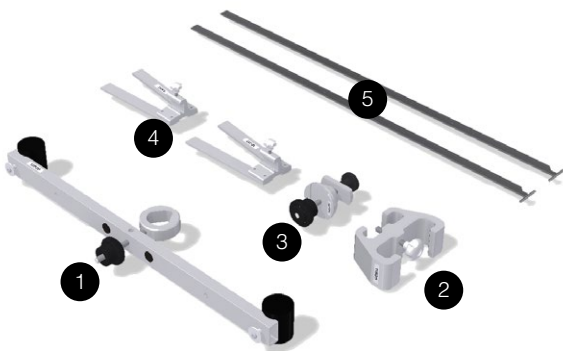

Adapter front, MAN TGA, Renault Magnum/D, Iveco Stralis, Mercedes Actros, Volvo FE

Adapter fram, MAN TGA, Renault Magnum/D, Iveco Stralis, Mercedes Actros, Volvo FE

Adapter Vorne, MAN TGA, Renault Magnum/D, Iveco Stralis, Mercedes Actros, Volvo FE

#	Article #	Order #	Pcs.	EN	SE	DE
1	AM1622	10360	1	Adapter TGA, Magnum/D, Stralis, Actros (only year model 2011 and later), Volvo FE	Adapter TGA, Magnum/D, Stralis, Actros (endast årsmodell 2011 och senare), Volvo FE	Halterung TGA, Magnum/D, Stralis, Actros (nur Modell des Jahres 2011 und später), Volvo FE









2 pcs of AM1622 are needed.

2 st AM1622 behövs.

2 Stück AM1622 sind notwendig.







Front adapters–Volvo Group Adapter fram–Volvo Group Adapter Vorne–Volvo Group

Make/modell/Modell	JT734 15876	AM1622 10360	AM1854 15167	JT733 15875	JT73305 16355	AM1780 10439	AM1862 15767
							
Volvo FE	(1 pc*)	2 pcs	—	—	—	—	—
Volvo FH (To/till/bis 2011)	—	—	—	—	—	2 pcs	—
Volvo FH (From/från/ab 2012)	—	—	2 pcs	—	—	—	—
Volvo FL	—	—	—	1 pc	—	—	—
Volvo FM (To/till/bis 2011)	—	—	—	—	—	2 pcs	—
Volvo FM (From/från/ab 2012)	—	—	2 pcs	—	—	—	—
Volvo FMX	—	—	2 pcs	—	—	—	—
Renault D narrow	1 pc	2 pcs	—	—	—	—	—
Renault D wide/C	—	—	—	1 pc	1 pc	—	—
Renault K	—	—	—	1 pc	—	—	—
Renault Premium Euro 6	—	—	—	—	—	—	2 pcs
Renault T & T-HIGH	—	—	2 pcs	—	—	—	—

* Only needed when thread is missing / Används endast när gänga saknas / Wird nur benötigt, wenn Gewinde fehlt

Front adapters–DAF, Iveco, MAN, Mercedes, Scania Adapter fram–DAF, Iveco, MAN, Mercedes, Scania Adapter Vorne–DAF, Iveco, MAN, Mercedes, Scania

Make/modell/Modell	AM1790 10444	AM1861 15658	AM1622 10360	AM1879 15875	JT510 12029
					
DAF CF-XF	2 pcs	—	—	—	—
DAF Euro 6	—	2 pcs	—	—	—
Iveco Stralis	—	—	(2 pcs*)	—	—
Iveco Trakker	—	—	—	—	1 pc
MAN TGA	—	—	2 pcs	—	—
Mercedes Actros	—	—	(2 pcs*)	—	1 pc
Scania 4/5/6	—	—	—	2 pcs	—

* Not guaranteed to fit all models / Kan inte garanteras passa till alla modeller / Es kann nicht garantiert werden, dass alle Modelle passen



Adapter front, Volvo FH/FM (to 2011)
Adapter fram, Volvo FH/FM (till 2011)
Adapter Vorne, Volvo FH/FM (bis 2011)

#	Article #	Order #	Pcs.	EN	SE	DE
1	AM1780	10439	1	Adapter, Volvo FH/FM (to 2011)	Adapter, Volvo FH/FM (till 2011)	Adapter Volvo FH/FM (bis 2011)

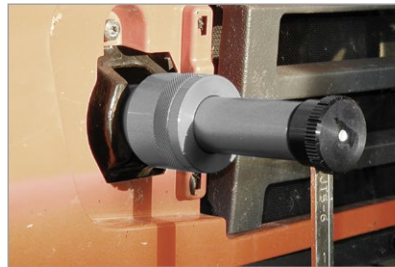

2 pcs of AM1780 are needed.

2 st AM1780 behövs.

2 Stück AM1780 sind notwendig.

Adapter front, Volvo FH/FMX/FM, Renault T & T-High (from 2012)
Adapter fram, Volvo FH/FMX/FM, Renault T & T-High (från 2012)
Adapter Vorne, Volvo FH/FMX/FM, Renault T & T-High (ab 2012)

#	Article #	Order #	Pcs.	EN	SE	DE
1	AM1854	15167	1	Adapter for Volvo FH/FMX/FM, Renault T & T-High (from 2012)	Adapter till Volvo FH/FMX/FM, Renault T & T-High (från 2012)	Adapter für Volvo FH/FMX/FM, Renault T & T-High (ab 2012)



2 pcs of AM1854 are needed.

2 st AM1854 behövs.

2 Stück AM1854 sind notwendig.



Adapter front, Volvo FL, Renault D wide and Renault K Adapter fram, Volvo FL, Renault D wide och Renault K Adapter Vorne, Volvo FL, Renault D wide und Renault K

#	Article #	Order #	Pcs.	EN	SE	DE
1	JT733	15875	1	Adapter for Volvo FL, Renault D wide and Renault K	Adapter till Volvo FL, Renault D bred och Renault K	Adapter für Volvo FL, Renault D breit und Renault K

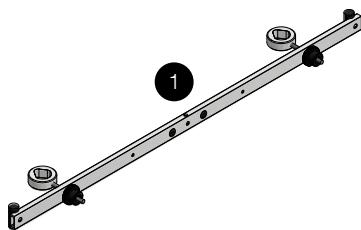

Adapter front, Renault D narrow Adapter fram, Renault D smal Adapter Vorne, Renault D schmal

#	Article #	Order #	Pcs.	EN	SE	DE
1	JT734	15876	1	Adapter for Renault D narrow	Adapter till Renault D smal	Adapter für Renault D schmal

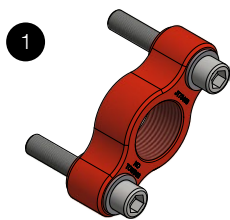

To be used together with 2 pcs of AM1622 when threaded mount plate not present.

Används tillsammans med 2 st AM1622 när gängad monteringsplatta saknas.

Wird mit 2 Stück AM1622 verwendet, wenn die Montageplatte mit Gewinde fehlt.



Adapter plate, Renault D wide/C Adapterplatta, Renault D bred/C Adapterplatte, Renault D breit/C

#	Article #	Order #	Pcs.	EN	SE	DE
1	JT73305	16355	1	Adapter plate for Renault D wide/C	Adapterplatta till Renault D bred/C	Adapterplatte für Renault D breit/C

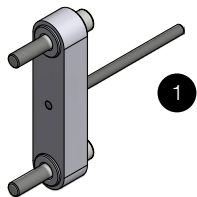

To be used together with 1 pc of JT733 if sprint mount not present on one side.

Används tillsammans med 1 st JT733 om sprintfäste saknas på en sida.

Wird mit 1 Stück JT733 verwendet, wenn die Sprint-Halterung auf einer Seite fehlt.

Adapter front, Renault Premium Euro 6 Adapter fram, Renault Premium Euro 6 Adapter Vorne, Renault Premium Euro 6

#	Article #	Order #	Pcs.	EN	SE	DE
1	AM1862	15767	1	Adapter for Renault Premium Euro 6	Adapter för Renault Premium Euro 6	Halterung für Renault Premium Euro 6



2 pcs of AM1862 are needed.

2 st AM1862 behövs.

2 Stück AM1862 sind notwendig.



Adapter front, DAF Euro 6 Adapter fram, DAF Euro 6 Adapter Vorne, DAF Euro 6

#	Article #	Order #	Pcs.	EN	SE	DE
1	AM1861	15658	1	Adapter for DAF Euro 6	Adapter för DAF Euro 6	Adapter für DAF Euro 6

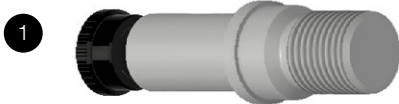

2 pcs of AM1861 are needed.

2 st AM1861 behövs.

2 Stück AM1861 sind notwendig.

Adapter front, DAF CF-XF Adapter fram, DAF CF-XF Adapter Vorne, DAF CF-XF

#	Article #	Order #	Pcs.	EN	SE	DE
1	AM1790	10444	1	Adapter for DAF, CF-XF	Adapter för DAF,CF-XF	Halterung für DAF,CF-XF



2 pcs of AM1790 are needed.

2 st AM1790 behövs.

2 Stück AM1790 sind notwendig.



Adapter front, Scania series 4/5/6

Adapter fram, Scania serie 4/5/6

Adapter Vorne, Scania Serie 4/5/6

#	Article #	Order #	Pcs.	EN	SE	DE
1	AM1879	16383	1	Adapter for Scania series 4/5/6	Adapter för Scania serie 4/5/6	Halterung für Scania Serie 4/5/6

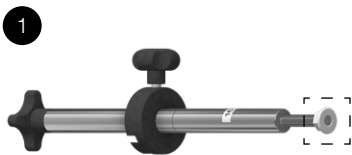

Scania series/serie/Serie 4/5



Scania series/serie/ Serie 6

Flange nut only needed for series 4/5.

Flänsmutter används bara till serie 4/5.

Flanschmutter nur für Serie 4/5 erforderlich.

2 pcs of AM1879 are needed.

2 st AM1879 behövs.

2 Stück AM1879 sind notwendig.